

DRUTEX S.A.

MB-86N SI BALCONY DOOR (NON-HVHZ)(NON-IMPACT)

GENERAL NOTES:

- THE PRODUCT SHOWN HEREIN IS DESIGNED AND MANUFACTURED TO COMPLY WITH THE CURRENT EDITION FLORIDA BUILDING CODE (FBC), EXCLUDING HVHZ AND HAS BEEN EVALUATED ACCORDING TO THE FOLLOWING:
 - AAMA/WDMA/CSA 101/I.S.2/A440-17
- ADEQUACY OF THE EXISTING STRUCTURAL CONCRETE/MASONRY, 2X FRAMING, AND METAL FRAMING AS A MAIN WIND FORCE RESISTING SYSTEM CAPABLE OF WITHSTANDING AND TRANSFERRING APPLIED PRODUCT LOADS TO THE FOUNDATION IS THE RESPONSIBILITY OF THE ENGINEER OR ARCHITECT OF RECORD FOR THE PROJECT OF INSTALLATION.
- 1X AND 2X BUCKS (WHEN USED) SHALL BE DESIGNED AND ANCHORED TO PROPERLY TRANSFER ALL LOADS TO THE STRUCTURE. BUCK DESIGN AND INSTALLATION IS THE RESPONSIBILITY OF THE ENGINEER OR ARCHITECT OF RECORD FOR THE PROJECT OF INSTALLATION.
- INSTALL INDIVIDUAL INSTALLATION ANCHORS WITHIN A TOLERANCE OF $\pm 1/4$ INCH OF THE DEPICTED LOCATION IN THE ANCHOR LAYOUT DETAIL (I.E., WITHOUT CONSIDERATION OF TOLERANCES). TOLERANCES ARE NOT CUMULATIVE FROM ONE INSTALLATION ANCHOR TO THE NEXT.
- THE INSTALLATION DETAILS DESCRIBED HEREIN ARE GENERIC AND MAY NOT REFLECT ACTUAL CONDITIONS FOR A SPECIFIC SITE. IF SITE CONDITIONS CAUSE INSTALLATION TO DEVIATE FROM THE REQUIREMENTS DETAILED HEREIN, A LICENSED ENGINEER OR ARCHITECT SHALL PREPARE SITE SPECIFIC DOCUMENTS FOR USE WITH THIS DOCUMENT.
- APPROVED IMPACT PROTECTIVE SYSTEM **IS REQUIRED** ON THIS PRODUCT IN AREAS REQUIRING IMPACT RESISTANCE.
- DOOR FRAME MATERIAL: ALUMINUM 6063-T5
- GLASS SHALL MEET THE REQUIREMENTS OF ASTM E 1300 GLASS CHARTS. SEE SHEET 1 FOR GLAZING DETAIL.
- CUSTOM SIZES AVAILABLE UPON REQUEST. CUSTOM DESIGN PRESSURE WILL BE ASSIGNED EQUAL TO NEXT LARGER STANDARD SIZE.

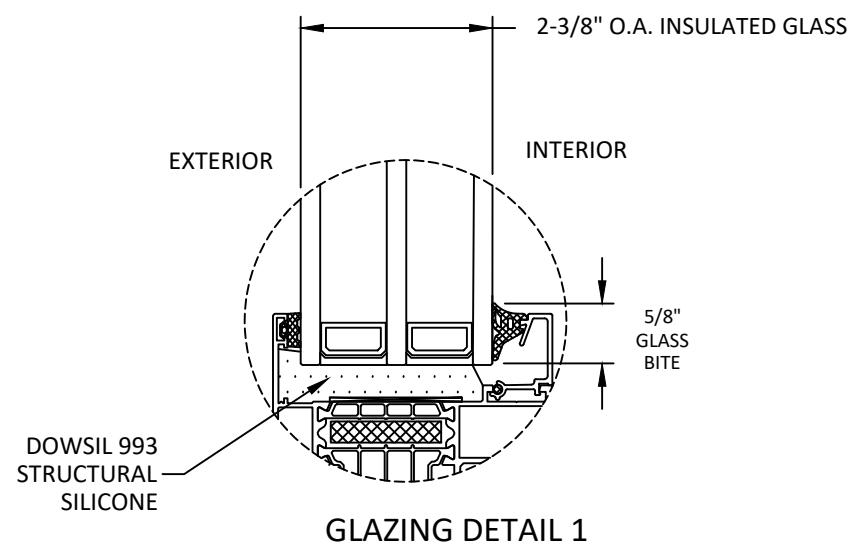

GLAZING NOTES:

- GLASS TYPE SHALL COMPLY WITH ASTM E1300 REQUIREMENTS. PER THE FBC TEMPER AND SAFETY GLAZING REQUIREMENTS SHALL BE REVIEWED ON A SITE SPECIFIC BASIS.
- SETTING BLOCK DUROMETER HARDNESS OF 70-90 (SHORE A) AS REFERENCED IN FBC CHAPTER 24.
- SETTING BLOCKS TO BE LOCATED AT 1/4 SPAN LENGTH FOR GLASS WIDER THAN 36" AS PER FBC CHAPTER 24.
- D.L.O. AND DESIGN PRESSURES MAY NOT EXCEED MAX VALUES SHOWN HEREIN.

TABLE OF CONTENTS	
SHEET	SHEET DESCRIPTION
1	GENERAL NOTES & GLAZING DETAIL
2	ELEVATIONS & DESIGN PRESSURE TABLES
3	ANCHOR LAYOUTS
4	VERTICAL SECTIONS
5	HORIZONTAL SECTIONS
6	INSTALLATION NOTES & ANCHOR DETAILS

CONFIGURATION	WIDTH (IN.)	HEIGHT (IN.)	DESIGN PRESSURE	MISSILE IMPACT RATING
XX	SEE TABLES ON SHEET 2			NON-IMPACT



LEBORSKA 31, 77-100
BYTOW, POLAND
PH: +48-59-822-9101 FX: +48-59-822-9103

TITLE: MB-86N SI
BALCONY DOOR
(NON-HVHZ) (NON-IMPACT)

GENERAL NOTES &
GLAZING DETAIL

PREPARED BY:
BUILDING DROPS, INC.
1900 NE MIAMI COURT, STE. 2-15
MIAMI, FL 33132
PH: (954) 399-8478
FAX: (954) 744-4738
WEB: www.buildingdrops.com



REMARKS	BY	DATE

THE INSTALLATION DETAILS DESCRIBED HEREIN ARE GENERIC AND MAY NOT REFLECT ACTUAL CONDITIONS FOR A SPECIFIC SITE. IF SITE CONDITIONS CAUSE INSTALLATION TO DEVIATE FROM THE REQUIREMENTS DETAILED HEREIN, A LICENSED ENGINEER OR ARCHITECT SHALL PREPARE SITE SPECIFIC DOCUMENTS FOR USE WITH THIS DOCUMENT.

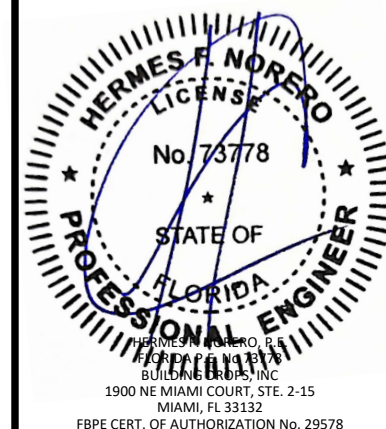

FL #:

FL46724

DATE: **03.19.24**

DWG. BY:
FB

CHK. BY:
HFN

SCALE: **NTS**

DWG. #: **DRU045**

SHEET:

1

OF 6

c:\users\franciscobreno\building_drops, inc\building_drops, landing - common\projects\drutex, s.a\bc-23-0705.1 - bc_submittal - mb79n.si.mb86n.si.aluminum.systems\dwgs\mb86n.mb86n - balcony_door\archive\dr045.dwg 5/1/2024 3:34 PM

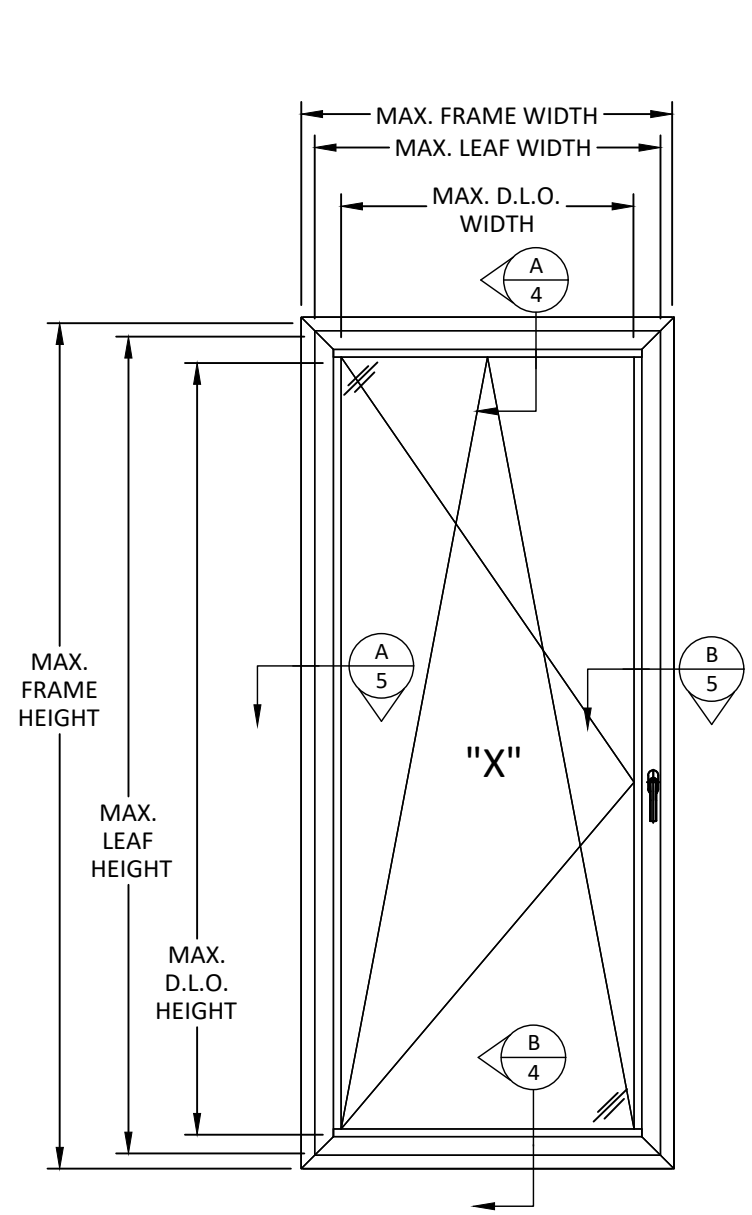

ELEVATIONS

LEAF HEIGHT = FRAME HEIGHT - 2.75"
 LEAF WIDTH = FRAME WIDTH - 2.75"
 D.L.O. HEIGHT = FRAME HEIGHT - 1.75"
 D.L.O. WIDTH = FRAME WIDTH - 1.75"

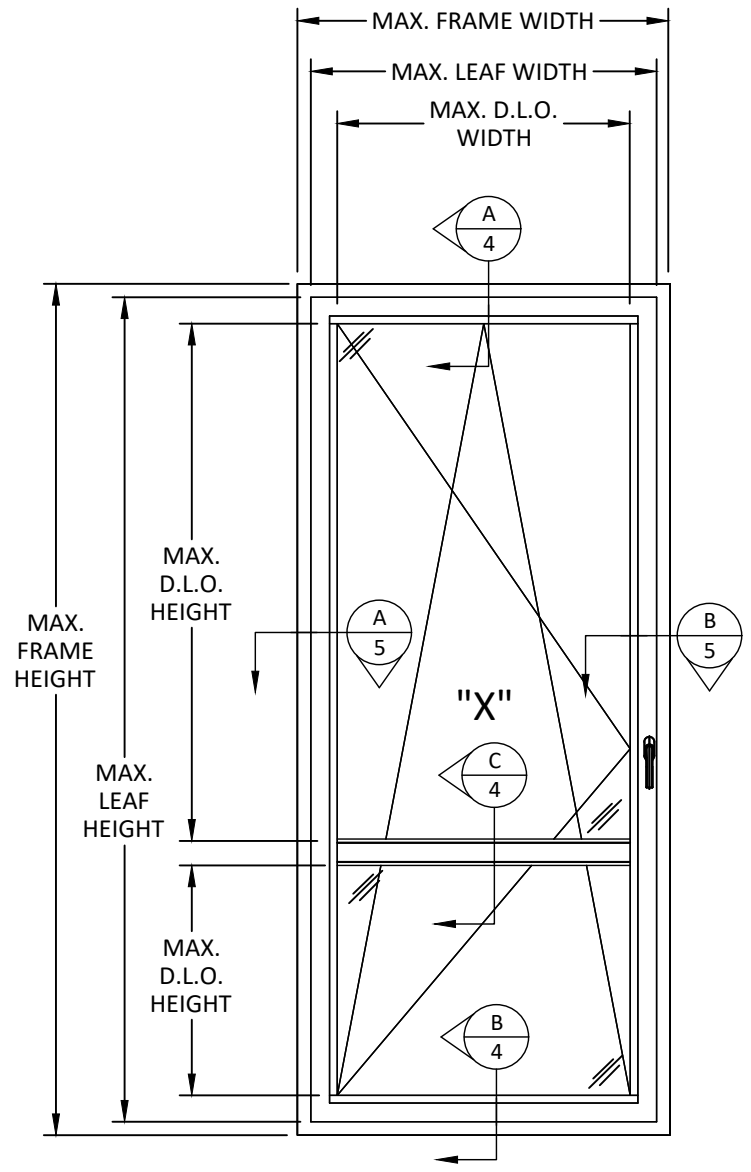

ELEVATIONS

FRAME DESIGN PRESSURES

DESIGN PRESSURE TABLE (PSF)		
NOMINAL DIMS.		POS.(+) NEG.(-)
FRAME WIDTH (IN.)	FRAME HEIGHT (IN.)	
24.00	72.00	70.00
30.00		70.00
36.00		70.00
41.00		70.00
48.00		59.79
54.00	53.15	
24.00	78.00	70.00
30.00		70.00
36.00		70.00
41.00		70.00
48.00		59.79
24.00	84.00	70.00
30.00		70.00
36.00		70.00
41.00		70.00
48.00		59.79
24.00	90.00	70.00
30.00		70.00
36.00		70.00
42.00		68.33
24.00		70.00
30.00	96.00	70.00
36.00		70.00
24.00		70.00
30.00		70.00
36.00		70.00
24.00	102.00	70.00
30.00		70.00
36.00		70.00
24.00		70.00
30.00		70.00
36.00	108.00	70.00
24.00		70.00
30.00		70.00
36.00		70.00
24.00		70.00
30.00	116.00	70.00
24.00		70.00
30.00		70.00
24.00		70.00
30.00		70.00
36.00	122.00	70.00
24.00		70.00
30.00		70.00
24.00		70.00
30.00		70.00
36.00	128.00	70.00
24.00		70.00
30.00		70.00
24.00		70.00
30.00		70.00
36.00	134.00	70.00
24.00		70.00
30.00		70.00
24.00		70.00
30.00		70.00

MID-RAIL GLASS SIZE DESIGN PRESSURES

DESIGN PRESSURE TABLE (PSF)		
NOMINAL DIMS.		POS.(+) NEG.(-)
D.L.O. WIDTH (IN.)	D.L.O. HEIGHT (IN.) ABOVE HORIZONTAL	
56	24	70.0
56	30	70.0
56	36	70.0
58	42	70.0
52	48	70.0
48	54	70.0
42	60	70.0
42	66	70.0
38	72	70.0



LEBORSKA 31, 77-100 BYTOW, POLAND
 PH: +48-59-822-9101 FX: +48-59-822-9103

TITLE: MB-86N SI BALCONY DOOR (NON-HVHZ) (NON-IMPACT)
 ELEVATIONS & DESIGN PRESSURE TABLES
 PREPARED BY: BUILDING DROPS, INC.
 1900 NE MIAMI COURT, STE. 2-15 MIAMI, FL 33132
 PH: (954) 399-8478 FAX: (954) 744-4738
 WEB: www.buildingdrops.com

REMARKS	BY	DATE

THE INSTALLATION DETAILS DESCRIBED HEREIN ARE GENERIC AND MAY NOT REFLECT ACTUAL CONDITIONS FOR A SPECIFIC SITE. IF SITE CONDITIONS CAUSE INSTALLATION TO DEVIATE FROM THE REQUIREMENTS DETAILED HEREIN, A LICENSED ENGINEER OR ARCHITECT SHALL PREPARE SITE SPECIFIC DOCUMENTS FOR USE WITH THIS DOCUMENT.

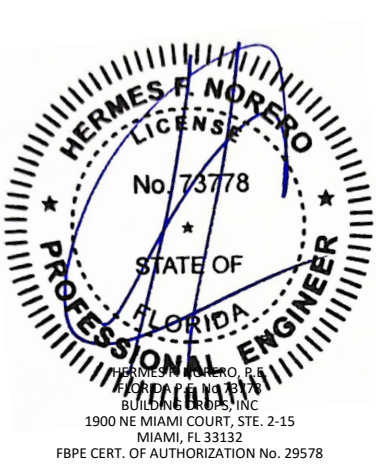

FL #: **FL46724**

DATE: **03.19.24**

DWG. BY: **FB** CHK. BY: **HFN**

SCALE: **NTS**

DWG. #: **DRU045**

SHEET: **2** OF 6

5/1/2024 3:34 PM
c:\users\franciscobreno\building_drops, inc\building_drops, inc\projects\drutex, s.a\fb-23-0705.1 - fb-submittal - mb79n-si-mb86n-si-aluminum_systems\dwgs\mb86n\mb86n - balcony_door\archive\dr045.dwg



LEBORSKA 31, 77-100
BYTOW, POLAND
PH: +48-59-822-9101 FX: +48-59-822-9103

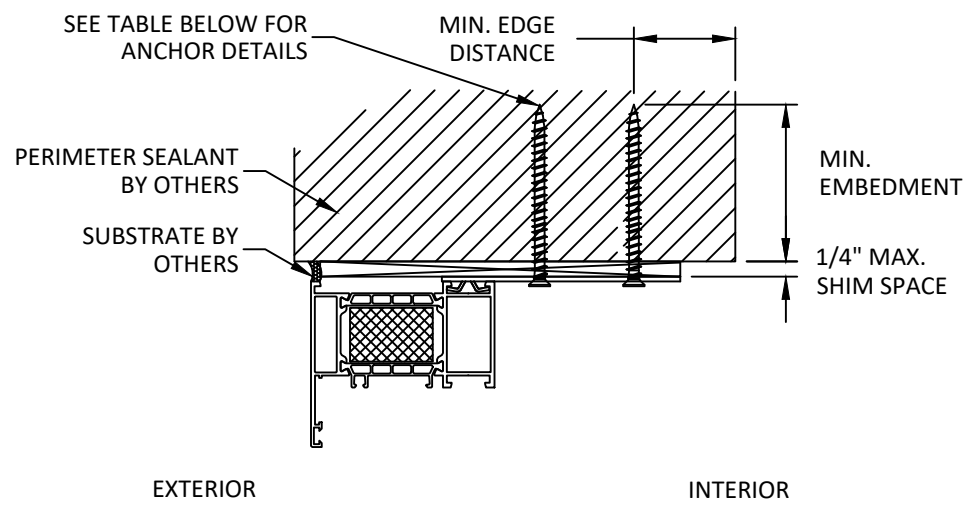

A
6 VERTICAL SECTION
THROUGH STRAP INSTALLATION

NOTE : SILL & JAMB SIMILAR

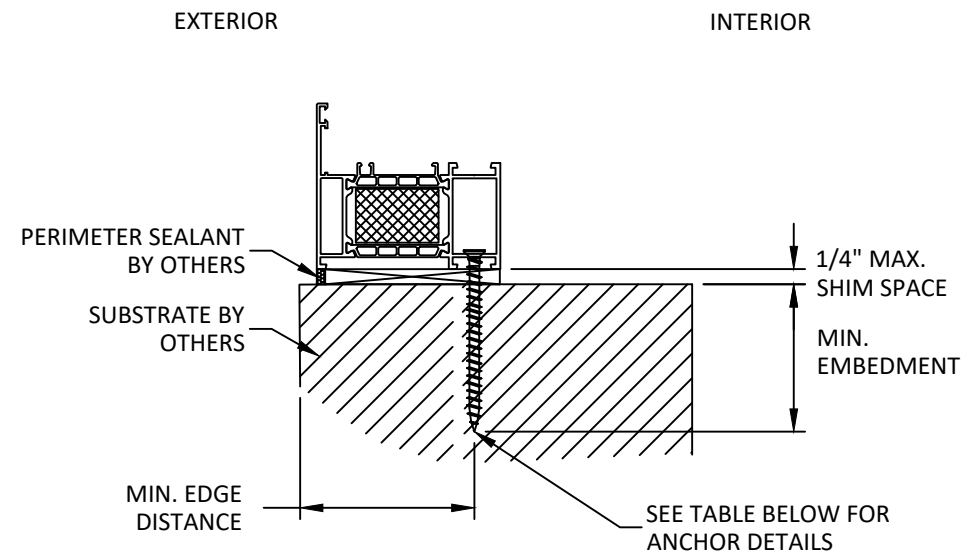

B
6 VERTICAL SECTION
THROUGH FRAME INSTALLATION

NOTE : HEAD & JAMB SIMILAR

INSTALLATION NOTES:

- ONE (1) INSTALLATION ANCHOR IS REQUIRED AT EACH ANCHOR LOCATION SHOWN, UNLESS OTHERWISE STATED ON SHEET 3.
- INSTALL INDIVIDUAL INSTALLATION ANCHORS WITHIN A TOLERANCE OF $\pm 1/2$ INCH THE DEPICTED LOCATION & SPACING IN THE ANCHOR LAYOUT DETAILS (I.E., WITHOUT CONSIDERATION OF TOLERANCES). TOLERANCES ARE NOT CUMULATIVE FROM ONE INSTALLATION ANCHOR TO THE NEXT.
- SHIM AS REQUIRED AT EACH INSTALLATION ANCHOR WITH LOAD BEARING SHIM(S). MAXIMUM ALLOWABLE SHIM STACK TO BE 1/4 INCH. SHIM WHERE SPACE OF 1/16 INCH OR GREATER OCCURS. SHIM(S) SHALL BE CONSTRUCTED OF HIGH DENSITY PLASTIC OR BETTER.
- MINIMUM EMBEDMENT AND EDGE DISTANCE EXCLUDE WALL FINISHES, INCLUDING BUT NOT LIMITED TO STUCCO, FOAM, BRICK VENEER, AND SIDING.
- INSTALLATION ANCHORS AND ASSOCIATED HARDWARE MUST BE MADE OF CORROSION RESISTANT MATERIAL OR HAVE A CORROSION RESISTANT COATING.
- FOR MASONRY OR CONCRETE OPENINGS, A 1X WOOD BUCK MAY BE USED (OPTIONAL) AS LONG AS THE MINIMUM EMBEDMENT AND EDGE DISTANCE REQUIREMENTS ARE STILL MET WITHIN THE CORRESPONDING HOST SUBSTRATE. SEE GENERAL NOTE #3 ON SHEET 1 FOR MORE INFORMATION.
- FOR HOLLOW BLOCK AND GROUT FILLED BLOCK, DO NOT INSTALL INSTALLATION ANCHORS INTO MORTAR JOINTS. EDGE DISTANCE IS MEASURED FROM FREE EDGE OF BLOCK OR EDGE OF MORTAR JOINT INTO FACE SHELL OF BLOCK.
- INSTALLATION ANCHORS SHALL BE INSTALLED IN ACCORDANCE WITH ANCHOR MANUFACTURER'S INSTALLATION INSTRUCTIONS, AND ANCHORS SHALL NOT BE USED IN SUBSTRATES WITH STRENGTHS LESS THAN THE MINIMUM STRENGTH SPECIFIED BY THE ANCHOR MANUFACTURER.

ANCHOR SCHEDULE				
METHOD	SUBSTRATE	ANCHOR TYPE	MIN. EMBEDMENT	MIN. EDGE DISTANCE
STRAP	WOOD: MIN. SG = 0.55	#8 WOOD SCREW	1.50"	0.75"
	METAL : 18 GA. STEEL MIN. Fy = 33 KSI ALUMINUM 1/8" MIN., 6063-T5	#8 SELF-DRILLING SCREW	3 THREADS MIN. PENETRATION BEYOND STRUCTURE	0.50"
	CONCRETE: f'c = 3000 PSI	3/16" ITW TAPCON	1.25"	2.00"
	MASONRY: CMU per ASTM C90 MIN. 2000 PSI	3/16" ITW TAPCON	1.00"	2.00"
THROUGH FRAME	WOOD: MIN. SG = 0.55	#12 WOOD SCREW	1.50"	0.75"
	METAL : 18 GA. STEEL MIN. Fy = 33 KSI ALUMINUM 1/8" MIN., 6063-T5	#12 SELF-DRILLING SCREW	3 THREADS MIN. PENETRATION BEYOND STRUCTURE	0.50"
	CONCRETE: f'c = 3000 PSI	3/16" ITW TAPCON	1.25"	2.00"
	MASONRY: CMU per ASTM C90 MIN. 2000 PSI	3/16" ITW TAPCON	1.00"	2.00"

TITLE: MB-86N SI
BALCONY DOOR
(NON-HVHZ) (NON-IMPACT)

INSTALLATION NOTES &
ANCHOR DETAILS

PREPARED BY:
BUILDING DROPS, INC.
1900 NE MIAMI COURT, STE. 2-15
MIAMI, FL 33132
PH: (954) 399-8478
FAX: (954) 744-4738
WEB: www.buildingdrops.com

REMARKS	BY	DATE

THE INSTALLATION DETAILS DESCRIBED HEREIN ARE GENERIC AND MAY NOT REFLECT ACTUAL CONDITIONS FOR A SPECIFIC SITE. IF SITE CONDITIONS CAUSE INSTALLATION TO DEVIATE FROM THE REQUIREMENTS DETAILED HEREIN, A LICENSED ENGINEER OR ARCHITECT SHALL PREPARE SITE SPECIFIC DOCUMENTS FOR USE WITH THIS DOCUMENT.

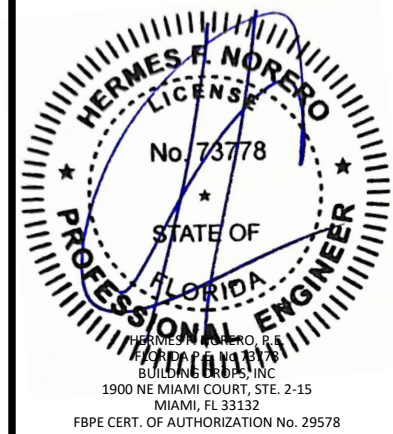

FL #:
FL46724

DATE: **03.19.24**

DWG. BY: **FB** CHK. BY: **HFN**

SCALE: **NTS**

DWG. #: **DRU045**

SHEET:
6
OF 6